

NOTES:
1. ALL DIMENSIONS IN MILLIMETRES.

TABLE 1
CHAMBER COVERS AND FRAMES TO BE:
a) SQUARE DUCTILE IRON WITH 600 mm CLEAR OPE. CLASS D400 TO I.S. EN 124:1994 BENEATH CARRIAGEWAYS, DRIVEWAYS AND FOOTWAYS.
b) SQUARE DUCTILE IRON WITH 600 mm CLEAR OPE. CLASS B125 TO I.S. EN 124:1994 BENEATH GRASSED AREAS

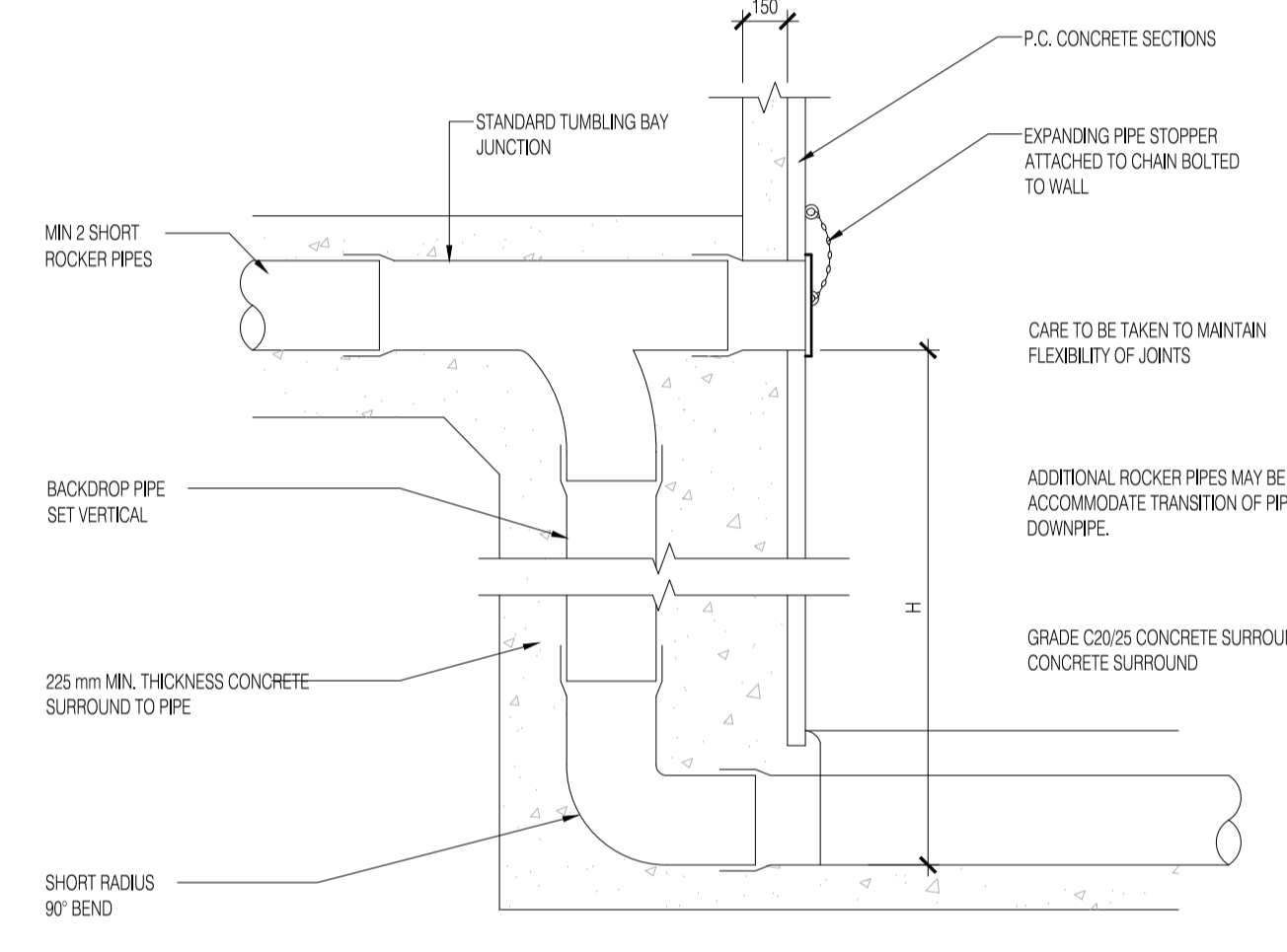
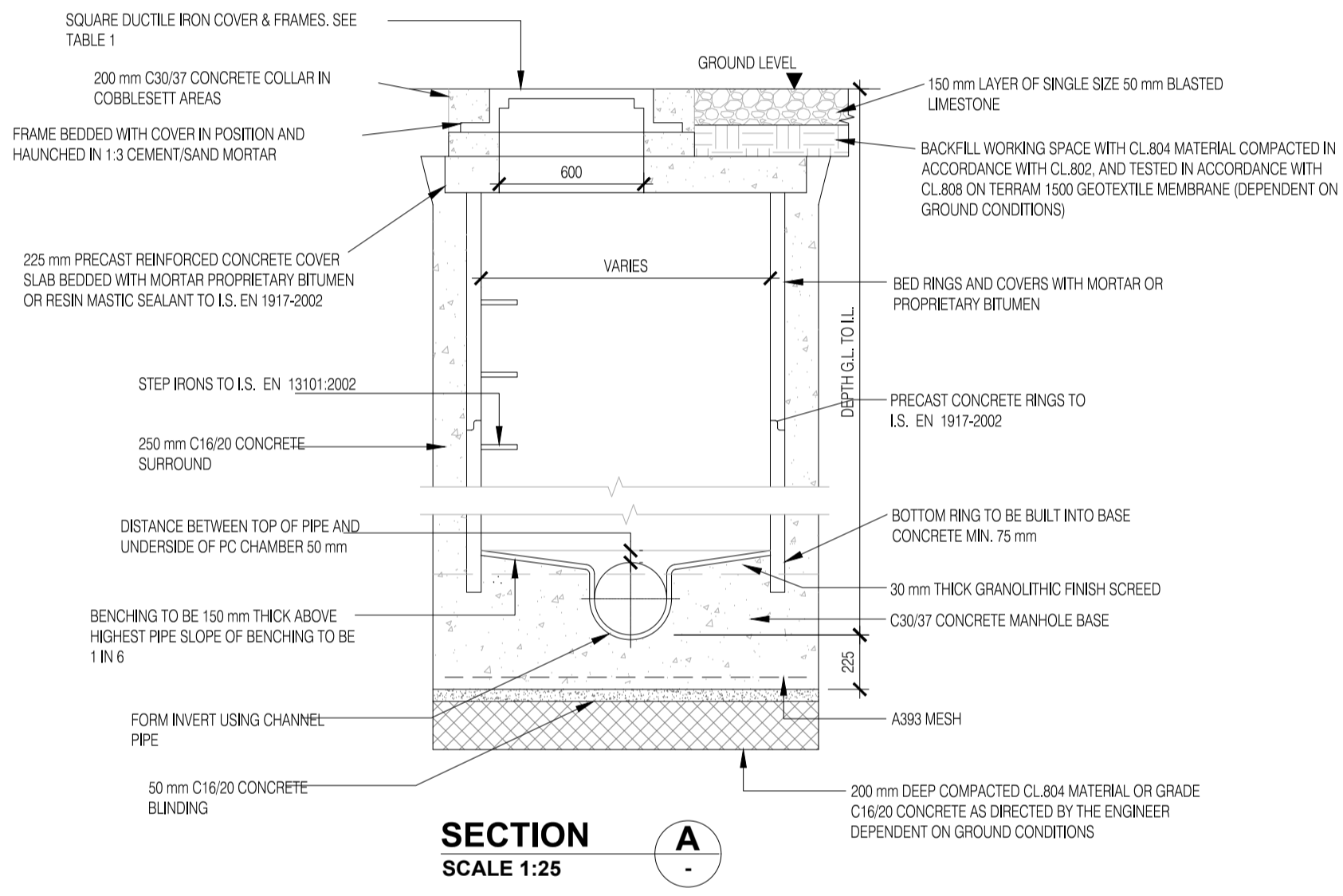
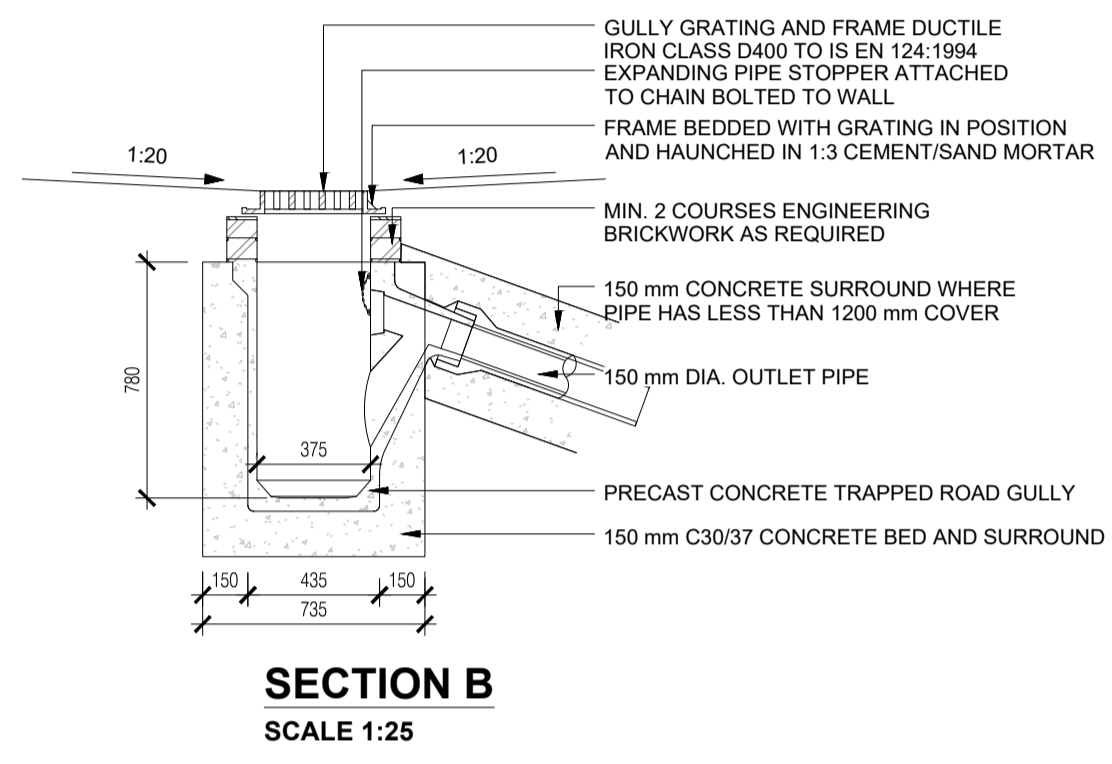
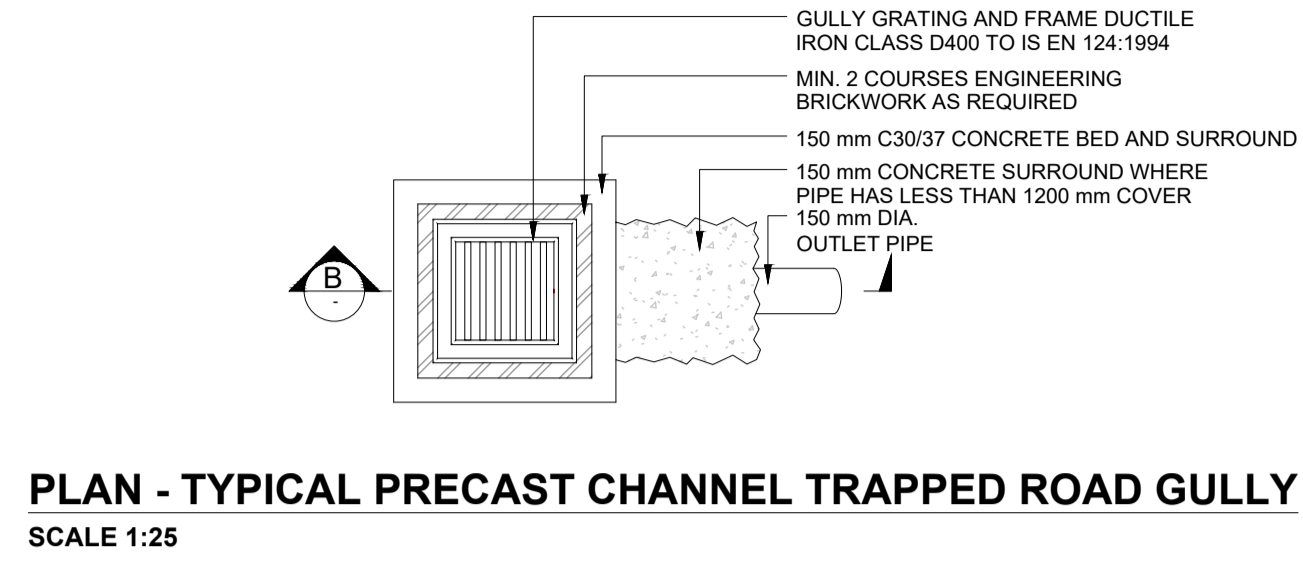
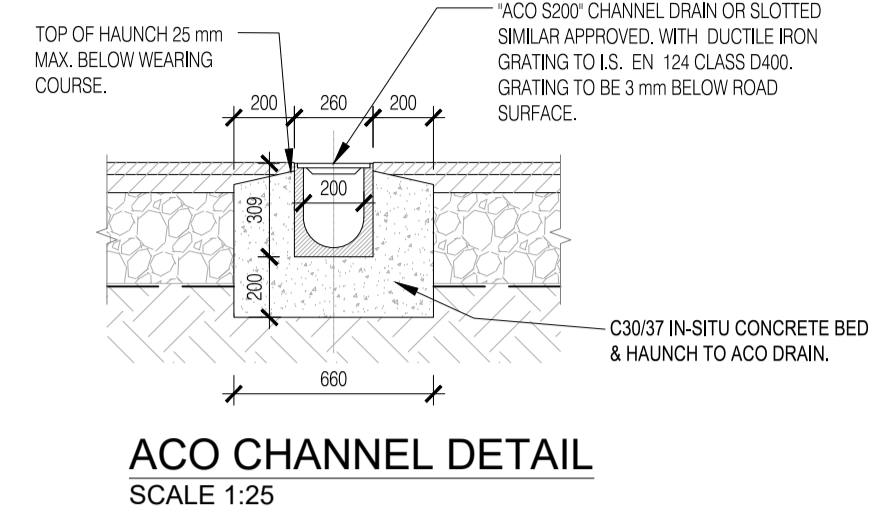
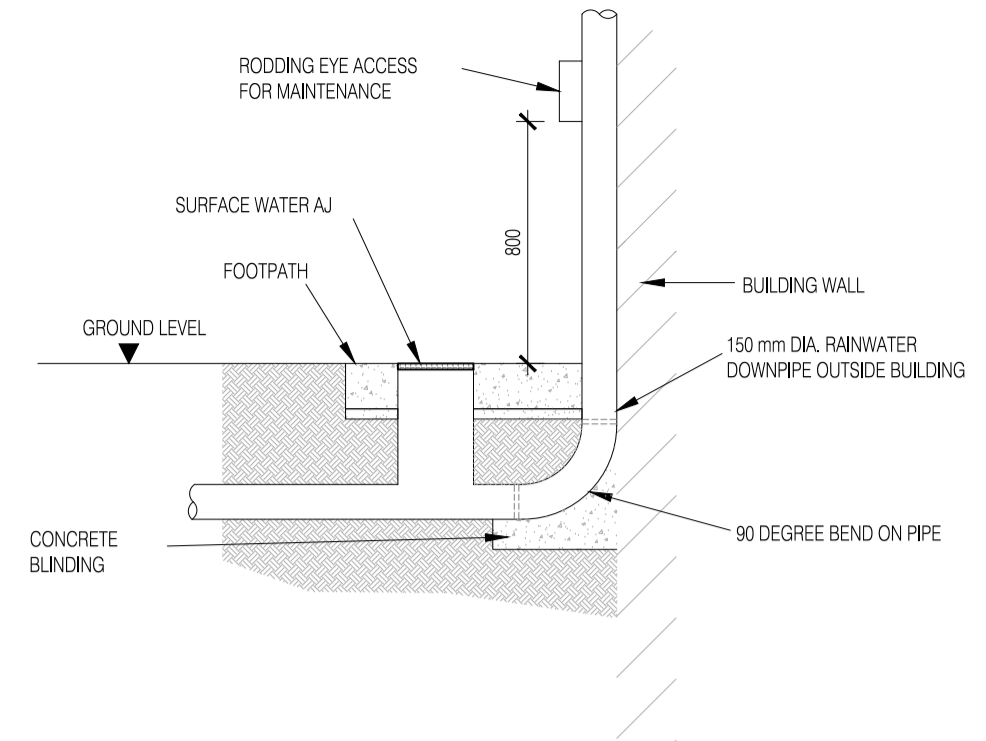
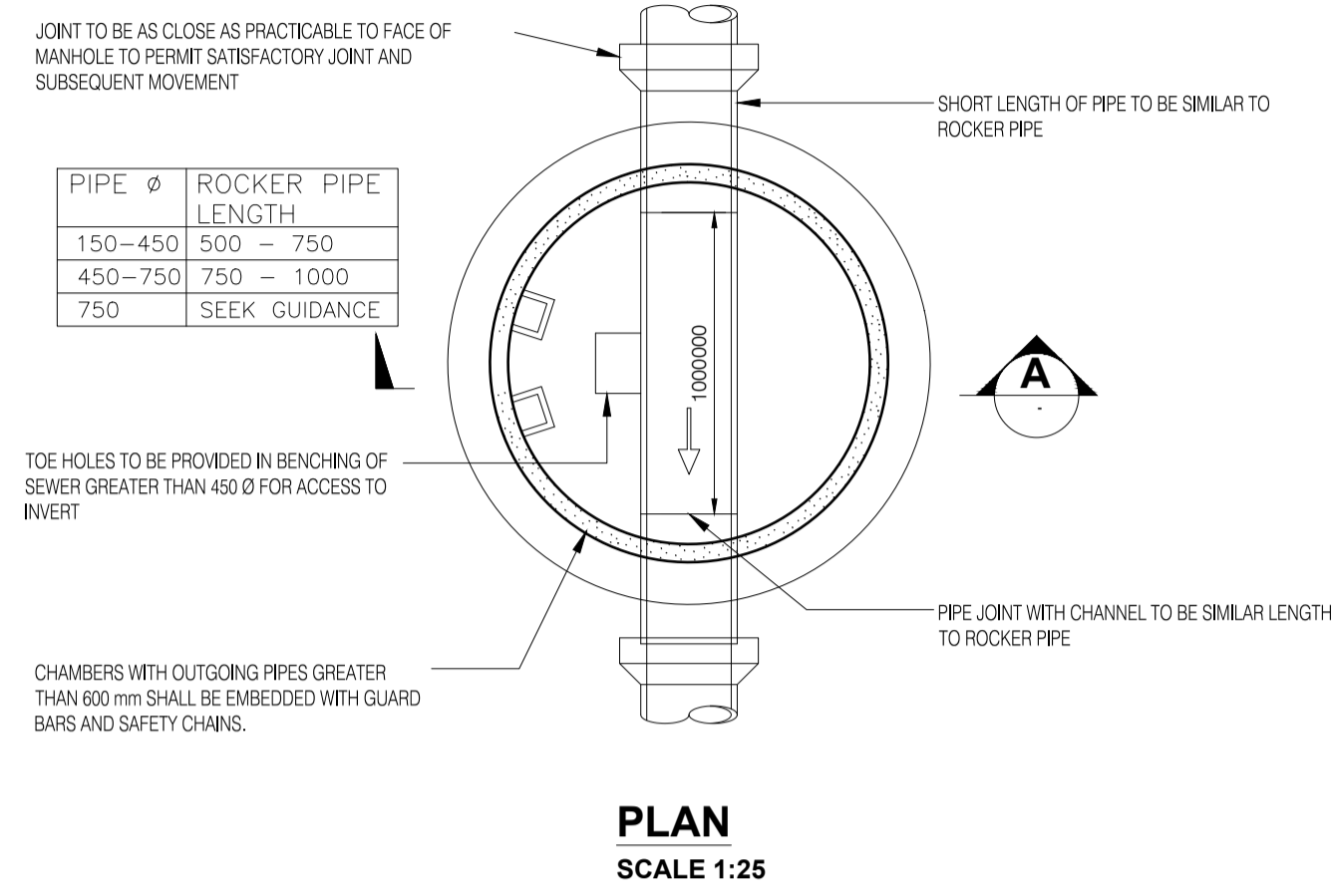

| INLET DIA | DROP DIA | H MIN |
|-----------|----------|-------|
| 150 | 150 | 600 |
| 300 | 300 | 600 |
| 375 | 300 | 750 |
| 450 | 300 | 750 |
| 525 | 450 | 750 |
| 600 | 450 | 750 |

TYPICAL PRECAST RING MANHOLE, DEPTH TO SOFFIT 0-3 m
SCALE 1:25

TYPICAL VERTICAL BACKDROP DETAIL
SCALE 1:25
(STEEPER GRADIENTS ARE PREFERRED TO THE USE OF BACKDROPS)

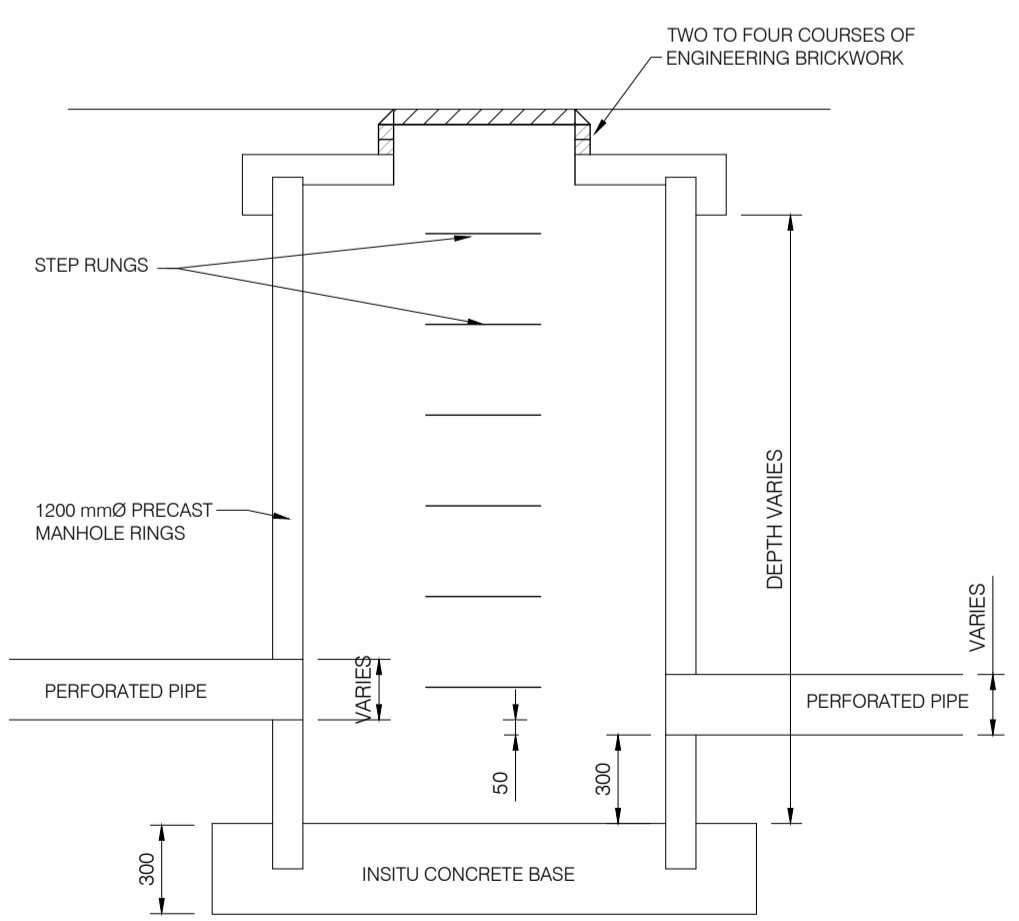

CATCHPIT - TYPICAL DETAIL
SCALE 1:25

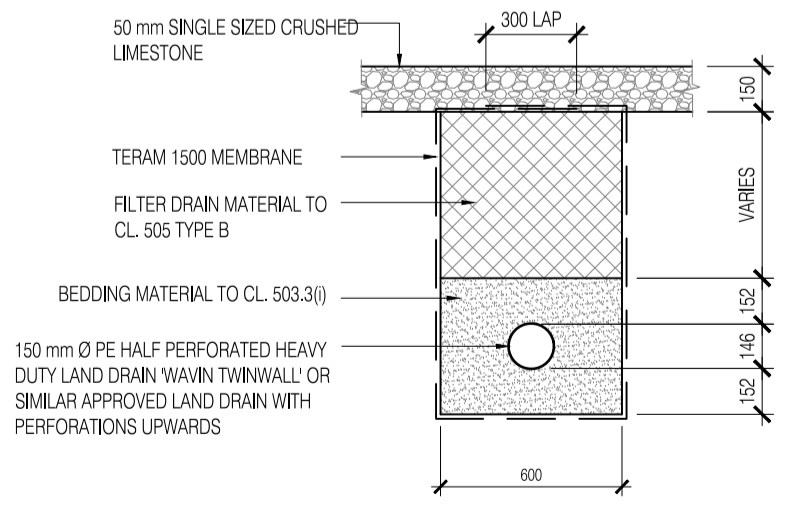

TYPICAL SECTION THROUGH LAND DRAIN
SCALE 1:25

| | | | | | | |
|-----|---------|----------------------|-----|------|-----|-----|
| 000 | 12-2023 | ISSUED FOR PLANNING | AB | HG | ED | JH |
| REV | DATE | REVISION DESCRIPTION | DRN | PROD | VER | APP |

COPYRIGHT © ESB
ALL RIGHTS RESERVED. NO PART OF THIS WORK MAY BE MODIFIED, REPRODUCED OR COPIED IN ANY FORM OR BY ANY MEANS - GRAPHIC, ELECTRONIC OR MECHANICAL, INCLUDING PHOTOCOPYING, RECORDING, TAPING OR USED FOR ANY PURPOSE OTHER THAN ITS DESIGNATED PURPOSE, WITHOUT THE WRITTEN PERMISSION OF ESB.

PURPOSE OF ISSUE - PRELIMINARY UNLESS INDICATED

CLIENT APPROVAL PLANNING TENDER CONSTRUCTION AS-BUILT

CLIENT: **ESB GENERATION & TRADING**

PROJECT: **MONEYPOINT SECURITY OF SUPPLY PROJECT**

CONTRACT:

DRAWING TITLE: **PROPOSED DRAINAGE DETAILS**

PRODUCTION UNIT: **CIVIL, ENVIRONMENTAL & RENEWABLE ENGINEERING**

ESB Engineering and Major Projects,
One Dublin Airport Central, Dublin Airport,
Cloghran, Co. Dublin, K67 XF72, Ireland.
Tel: +353 (0)1 703 8000 Web: www.esb.ie
Engineering and Major Projects is a division of ESB.

| | | | | |
|-----------|-----------|-----------|------------|---------------|
| DRAWN | PRODUCED | VERIFIED | APPROVED | APPROVAL DATE |
| A. Buttur | H.Griffin | E. Dunphy | J. Haverty | Dec 2023 |

| | | | |
|------------|-------------|------|----------|
| CLIENT REF | NO. OF SHTS | SIZE | SCALE |
| | 1 | A1 | AS SHOWN |

| | | |
|-------------------------------|-------|-----|
| DRAWING NUMBER | SHEET | REV |
| QP-000017-65-D451-010-001-000 | 1 | 1 |